

Washoe County Development Application

Your entire application is a public record. If you have a concern about releasing personal information, please contact Planning and Building staff at 775.328.6100.

| | | | |
|---|-----------------|---------------------------------------|-----------------|
| Project Information | | Staff Assigned Case No.: _____ | |
| Project Name: SC009320A (Red Peak West) | | | |
| Project Description: Remove and replace existing 15' T-Mobile tower with a new 40' monopole. Install (6) new antennas on tower and install (4) new radios on new tower. | | | |
| Project Address: 2000 First Avenue, Sparks, NV 89431 | | | |
| Project Area (acres or square feet): 20' x 20' (400 square feet) | | | |
| Project Location (with point of reference to major cross streets AND area locator): 2000 W First Ave and McGuffey Road | | | |
| Assessor's Parcel No.(s): | Parcel Acreage: | Assessor's Parcel No.(s): | Parcel Acreage: |
| 502-250-08 | 12.63 | | |
| Indicate any previous Washoe County approvals associated with this application: Case No.(s). | | | |
| Applicant Information (attach additional sheets if necessary) | | | |
| Property Owner: Desert View Commercial Properties, LLC | | Professional Consultant: | |
| Name: Dave Metts | | Name: | |
| Address: | | Address: | |
| Zip: | | Zip: | |
| Phone: 775-315-6319 | Fax: | Phone: | Fax: |
| Email: dmetts@hdiss.net | | Email: | |
| Cell: 775-315-6319 | Other: | Cell: | Other: |
| Contact Person: Dave Metts | | Contact Person: | |
| Applicant/Developer: 51 Wireless, LLC. | | Other Persons to be Contacted: | |
| Name: Nick Tagas | | Name: | |
| Address: 4040 Bonanza Way | | Address: | |
| Loomis, CA | Zip: 95650 | | Zip: |
| Phone: 916-990-1446 | Fax: | Phone: | Fax: |
| Email: Nick.Tagas@51wireless.net | | Email: | |
| Cell: 916-990-1446 | Other: | Cell: | Other: |
| Contact Person: Nick Tagas | | Contact Person: | |
| For Office Use Only | | | |
| Date Received: | Initial: | Planning Area: | |
| County Commission District: | | Master Plan Designation(s): | |
| CAB(s): | | Regulatory Zoning(s): | |

Special Use Permit Application Supplemental Information

(All required information may be separately attached)

1. What is the project being requested?

To remove an existing 15' tall tower owned by T-Mobile within an existing 20' x 20' compound leased by T-Mobile and replace it with a new 40' monopole. 6 new antennas and 4 new radios will be installed on the new tower once it is constructed.

2. Provide a site plan with all existing and proposed structures (e.g. new structures, roadway improvements, utilities, sanitation, water supply, drainage, parking, signs, etc.)

See attached plan set date 8-6-2020

3. What is the intended phasing schedule for the construction and completion of the project?

May 2021 or sooner based on weather conditions. Construction will take approx 12 - 14 weeks.

4. What physical characteristics of your location and/or premises are especially suited to deal with the impacts and the intensity of your proposed use?

This 12 acre parcel has approx 10 existing cellular and communication towers on this peak. There already exists an improved access road leading up to the site

5. What are the anticipated beneficial aspects or affects your project will have on adjacent properties and the community?

Improved 4G LTE coverage and capacity for T-Mobile customers living in Washoe County. In-building, outdoor, as well as in transit coverage will be greatly enhanced. This tower upgrade will improve a significant coverage and capacity gap in this area for T-Mobile and their customers.

6. What are the anticipated negative impacts or affect your project will have on adjacent properties? How will you mitigate these impacts?

None. This area on Red Peak is already encumbered with multiple cell towers ranging in heights exceeding 60 - 90 feet. T-Mobile's tower will be well below the heights of the other existing towers. Also due to the remoteness of this location will have no negative impacts on nearby commercial and residential parcels.

7. Provide specific information on landscaping, parking, type of signs and lighting, and all other code requirements pertinent to the type of use being purposed. Show and indicate these requirements on submitted drawings with the application.

No landscaping is required. This tower sits on a mountain top ridge with an already improved gravel driveway leading up to the site with sufficient parking for technicians and crews who might need to upgrade, operate, or otherwise inspect the facility(s).

8. Are there any restrictive covenants, recorded conditions, or deed restrictions (CC&Rs) that apply to the area subject to the special use permit request? (If so, please attach a copy.)

| | |
|------------------------------|--|
| <input type="checkbox"/> Yes | <input checked="" type="checkbox"/> No |
|------------------------------|--|

9. Utilities:

| | |
|---------------------------------|-----|
| a. Sewer Service | N/A |
| b. Electrical Service | N/A |
| c. Telephone Service | N/A |
| d. LPG or Natural Gas Service | N/A |
| e. Solid Waste Disposal Service | N/A |
| f. Cable Television Service | N/A |
| g. Water Service | N/A |

For most uses, Washoe County Code, Chapter 110, Article 422, Water and Sewer Resource Requirements, requires the dedication of water rights to Washoe County. Please indicate the type and quantity of water rights you have available should dedication be required.

| | | | |
|--------------------|--|--------------------|--|
| h. Permit # | | acre-feet per year | |
| i. Certificate # | | acre-feet per year | |
| j. Surface Claim # | | acre-feet per year | |
| k. Other # | | acre-feet per year | |

Title of those rights (as filed with the State Engineer in the Division of Water Resources of the Department of Conservation and Natural Resources).

| |
|---------------------------|
| Intentionally left blank. |
|---------------------------|

10. Community Services (provided and nearest facility):

| | |
|-------------------------|--|
| a. Fire Station | Reno Fire Department Station 10 (5250 N Virginia Street) |
| b. Health Care Facility | West Hills Hospital (1240 E 9th Street) |
| c. Elementary School | Lois Allen Elementary School (5155 McGuffey Road) |
| d. Middle School | Desert Skies Middle School (7550 Donatello Drive) |
| e. High School | North Valleys High School (1470 E Golden Valley Road) |
| f. Parks | Panther Valley Park (400 Western Road) |
| g. Library | TMCC Elizabeth Sturm Library (7000 Dandini Road) |
| h. Citifare Bus Stop | North Virginia Street and E Parr Boulevard |

**Special Use Permit Application
for Grading**

Supplemental Information

(All required information may be separately attached)

1. What is the purpose of the grading?

Minor grading for new tower foundation.

2. How many cubic yards of material are you proposing to excavate on site?

TBD

3. How many square feet of surface of the property are you disturbing?

400 sq. ft.

4. How many cubic yards of material are you exporting or importing? If none, how are you managing to balance the work on-site?

TBD

5. Is it possible to develop your property without surpassing the grading thresholds requiring a Special Use Permit? (Explain fully your answer.)

Again amount of grading TBD but very minor grading as area is already improved.

6. Has any portion of the grading shown on the plan been done previously? (If yes, explain the circumstances, the year the work was done, and who completed the work.)

Yes. Entire area is a graded and improved cell tower farm with multiple towers on this property.

7. Have you shown all areas on your site plan that are proposed to be disturbed by grading? (If no, explain your answer.)

Yes.

8. Can the disturbed area be seen from off-site? If yes, from which directions and which properties or roadways?

No.

9. Could neighboring properties also be served by the proposed access/grading requested (i.e. if you are creating a driveway, would it be used for access to additional neighboring properties)?

No.

10. What is the slope (horizontal/vertical) of the cut and fill areas proposed to be? What methods will be used to prevent erosion until the revegetation is established?

TBD

11. Are you planning any berms?

| | | |
|-----|--|--|
| Yes | No <input checked="" type="checkbox"/> | If yes, how tall is the berm at its highest? |
|-----|--|--|

12. If your property slopes and you are leveling a pad for a building, are retaining walls going to be required? If so, how high will the walls be and what is their construction (i.e. rockery, concrete, timber, manufactured block)?

N/A

13. What are you proposing for visual mitigation of the work?

N/A

14. Will the grading proposed require removal of any trees? If so, what species, how many and of what size?

No.

15. What type of revegetation seed mix are you planning to use and how many pounds per acre do you intend to broadcast? Will you use mulch and, if so, what type?

N/A

16. How are you providing temporary irrigation to the disturbed area?

N/A

17. Have you reviewed the revegetation plan with the Washoe Storey Conservation District? If yes, have you incorporated their suggestions?

N/A

18. Are there any restrictive covenants, recorded conditions, or deed restrictions (CC&Rs) that may prohibit the requested grading?

| | | |
|-----|--|-------------------------------|
| Yes | No <input checked="" type="checkbox"/> | If yes, please attach a copy. |
|-----|--|-------------------------------|

**Special Use Permit Application for Stables
Supplemental Information**

(All required information may be separately attached)

1. What is the maximum number of horses to be boarded, both within stables and pastured?

2. What is the maximum number of horses owned/maintained by the owner/operator of the project, both within stables and pastured?

3. List any ancillary or additional uses proposed (e.g., tack and saddle sales, feed sales, veterinary services, etc.). Only those items that are requested may be permitted.

4. If additional activities are proposed, including training, events, competition, trail rides, fox hunts, breaking, roping, etc., only those items that are requested may be permitted. Clearly describe the number of each of the above activities which may occur, how many times per year and the number of expected participants for each activity.

5. What currently developed portions of the property or existing structures are going to be used with this permit?

6. To what uses (e.g., restrooms, offices, managers living quarters, stable area, feed storage, etc.) will the barn be put and will the entire structure be allocated to those uses? (Provide floor plans with dimensions).

7. Where are the living quarters for the operators of the stables and where will employees reside?

8. How many improved parking spaces, both on-site and off-site, are available or will be provided? (Please indicate on site plan.) Have you provided for horse trailer turnarounds?

9. What are the planned hours of operation?

10. What improvements (e.g. new structures including the square footage, roadway/driveway improvements, utilities, sanitation, water supply, drainage, parking, signs, etc.) will have to be constructed or installed and what is the projected time frame for the completion of each?

11. What is the intended phasing schedule for the construction and completion of the project?

12. What physical characteristics of your location and/or premises are especially suited to deal with the impacts and the intensity of your proposed use?

13. What are the anticipated beneficial aspects or affects your project will have on adjacent properties and the community?

14. What are the adverse impacts upon the surrounding community (including traffic, noise, odors, dust, groundwater contamination, flies, rats, mice, etc.) and what will you do to minimize the anticipated negative impacts or effects your project will have on adjacent properties?

15. Please describe operational parameters and/or voluntary conditions of approval to be imposed on the administrative permit to address community impacts.

16. What types of landscaping (e.g. shrubs, trees, fencing, painting scheme, etc.) are proposed? (Please indicate location on site plan.)

| |
|--|
| |
|--|

17. What type of signs and lighting will be provided? On a separate sheet, show a depiction (height, width, construction materials, colors, illumination methods, lighting intensity, base landscaping, etc.) of each sign and the typical lighting standards. (Please indicate location of signs and lights on site plan.)

| |
|--|
| |
|--|

18. Are there any restrictive covenants, recorded conditions, or deed restrictions (CC&Rs) that apply to the area subject to the administrative permit request? (If so, please attach a copy.)

| | |
|------------------------------|-----------------------------|
| <input type="checkbox"/> Yes | <input type="checkbox"/> No |
|------------------------------|-----------------------------|

19. Community Sewer

| | |
|------------------------------|-----------------------------|
| <input type="checkbox"/> Yes | <input type="checkbox"/> No |
|------------------------------|-----------------------------|

20. Community Water

| | |
|------------------------------|-----------------------------|
| <input type="checkbox"/> Yes | <input type="checkbox"/> No |
|------------------------------|-----------------------------|

Washoe County Treasurer
 P.O. Box 30039, Reno, NV 89520-3039
 ph: (775) 328-2510 fax: (775) 328-2500
 Email: tax@washoecounty.us

Washoe County Treasurer
 Tammi Davis

Bill Detail

[Back to Account Detail](#)

[Change of Address](#)

[Print this Page](#)

Washoe County Parcel Information

| | | |
|--|----------------|---|
| Parcel ID | Status | Last Update |
| 50225008 | Active | 8/13/2020 1:41:08 AM |
| Current Owner: DESERT VIEW COMMERCIAL PROPERTIES LLC 1032 DUCK HILL RD WASHOE VALLEY, NV 89704 | | SITUS: 2000 W 1ST AVE WASHOE COUNTY NV |
| Taxing District 4000 | Geo CD: | |
| Legal Description | | |
| Township 20 Section Lot 3 Block Range 19 SubdivisionName _UNSPECIFIED | | |

Installments

| Period | Due Date | Tax Year | Tax | Penalty/Fee | Interest | Total Due |
|-------------------|-----------|----------|-------------------|---------------|---------------|-------------------|
| INST 1 | 8/17/2020 | 2020 | \$2,241.42 | \$0.00 | \$0.00 | \$2,241.42 |
| INST 2 | 10/5/2020 | 2020 | \$2,241.39 | \$0.00 | \$0.00 | \$2,241.39 |
| INST 3 | 1/4/2021 | 2020 | \$2,241.38 | \$0.00 | \$0.00 | \$2,241.38 |
| INST 4 | 3/1/2021 | 2020 | \$2,241.38 | \$0.00 | \$0.00 | \$2,241.38 |
| Total Due: | | | \$8,965.57 | \$0.00 | \$0.00 | \$8,965.57 |

Tax Detail

| | Gross Tax | Credit | Net Tax |
|---|-------------------|---------------|-------------------|
| State of Nevada | \$470.38 | \$0.00 | \$470.38 |
| Truckee Meadows Fire Dist | \$1,494.16 | \$0.00 | \$1,494.16 |
| Washoe County | \$3,850.80 | \$0.00 | \$3,850.80 |
| Washoe County Sc | \$3,150.20 | \$0.00 | \$3,150.20 |
| TRUCKEE MDWS/SUN VALLEY WATER BASIN | \$0.03 | \$0.00 | \$0.03 |
| Total Tax | \$8,965.57 | \$0.00 | \$8,965.57 |

Payment History

No Payment Records Found

Pay By Check

Please make checks payable to:
WASHOE COUNTY TREASURER

Mailing Address:
 P.O. Box 30039
 Reno, NV 89520-3039

Overnight Address:
 1001 E. Ninth St., Ste D140
 Reno, NV 89512-2845

Change of Address

All requests for a mailing address change must be submitted in writing, including a signature (unless using the online form).

To submit your address change online [click here](#)

Address change requests may also be faxed to: (775) 328-3642

Address change requests may also be mailed to: Washoe County Assessor
 1001 E 9th Street
 Reno, NV 89512-2845

The Washoe County Treasurer's Office makes every effort to produce and publish the most current and accurate information possible. No warranties, expressed or implied, are provided for the data herein, its use, or its interpretation. If you have any questions, please contact us at (775) 328-2510 or tax@washoecounty.us

This site is best viewed using Google Chrome, Internet Explorer 11, Mozilla Firefox or Safari.

PROPRIETARY INFORMATION
 THE INFORMATION CONTAINED IN THIS SET OF DRAWINGS IS PROPRIETARY BY NATURE. ANY USE OR DISCLOSURE OTHER THAN THAT WHICH RELATES TO PEAK SITE-COM IS STRICTLY PROHIBITED

CLIENT:

T-Mobile
T-MOBILE WEST LLC
 1765 Creekside Oaks Drive, Suite 190 • Sacramento, CA 95833

PROJECT INFORMATION:

RED PEAK WEST
 2000 FIRST AVE
 SPARKS, NEVADA 89431

REV. DATE DESCRIPTION BY

| REV. | DATE | DESCRIPTION | BY |
|------|---------|--------------|-----|
| 1 | 7-15-20 | 90% CDS | ALP |
| 2 | 8-3-20 | 100% CDS | VRT |
| 3 | 8-6-20 | rev 100% CDS | VRT |
| | | | |
| | | | |
| | | | |
| | | | |
| | | | |
| | | | |
| | | | |
| | | | |
| | | | |

COORDINATING ENGINEER:

Peek Site-Com
 12852 Earhart Ave. Suite 101
 Auburn, California 95602
 Phone (530) 885-6160
 E-Mail info@peeksitecom.com

SEAL:

SITE # CHK. DRAWN BY

SC09320 ... ALP

SHEET TITLE:

DETAILS

SHEET NUMBER: REVISION:

A-3.2 0

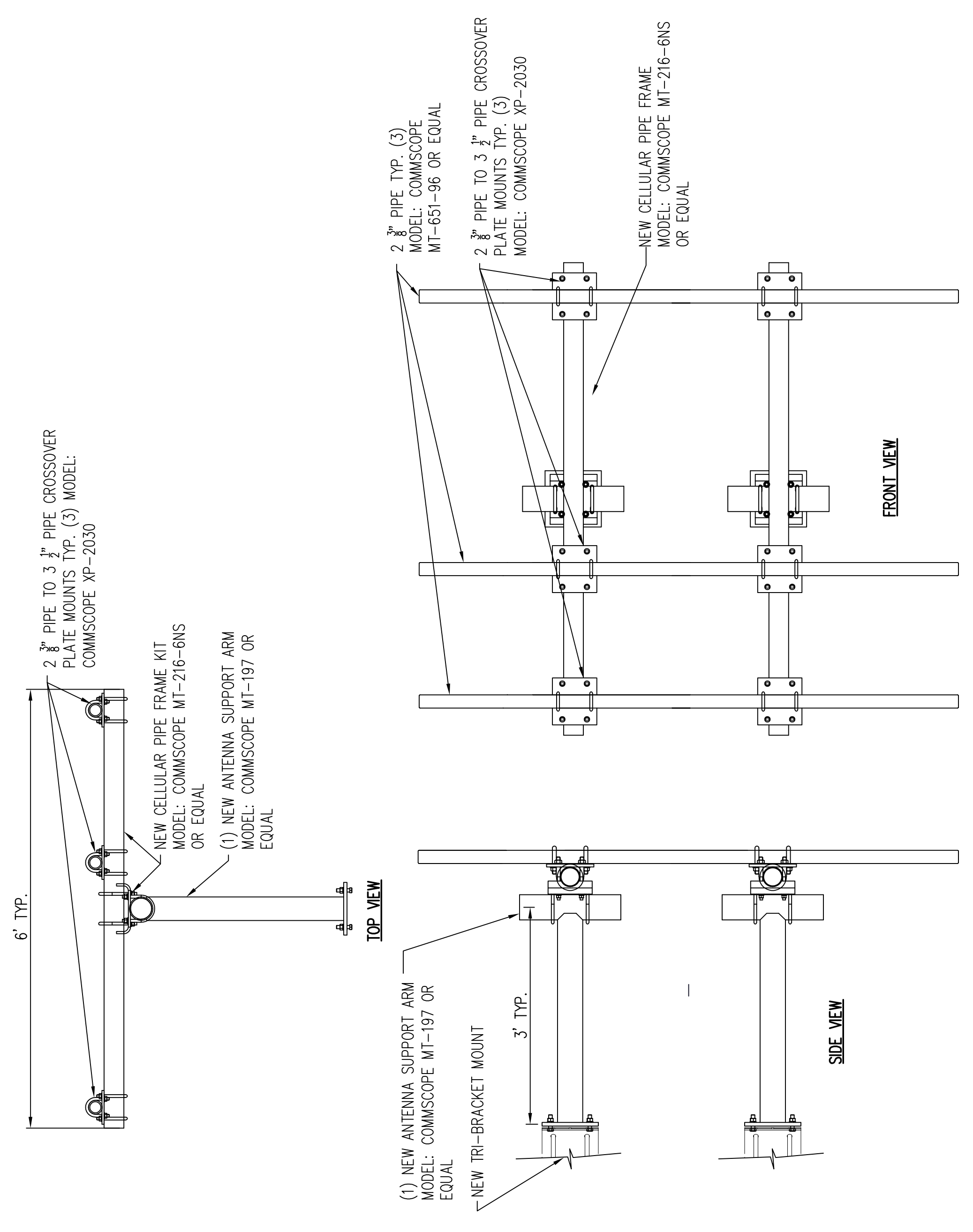

| ITEM | PART NO. | DESCRIPTION | QTY. | WEIGHT |
|------|------------|------------------------------|------|-----------|
| 1 | MCRH030403 | 1030-4 Ringmount Veldment | 4 | 24.82 LBS |
| 2 | MT-384-20 | 3/4" X 20" GALV THREADED ROD | 8 | 2.48 LBS |
| 3 | 5WL-06 | 3/4" GALV LOCK WASHER | 16 | 0.09 LBS |
| 4 | EN-06 | 3/4" GALV HEX NUT | 16 | 0.33 LBS |

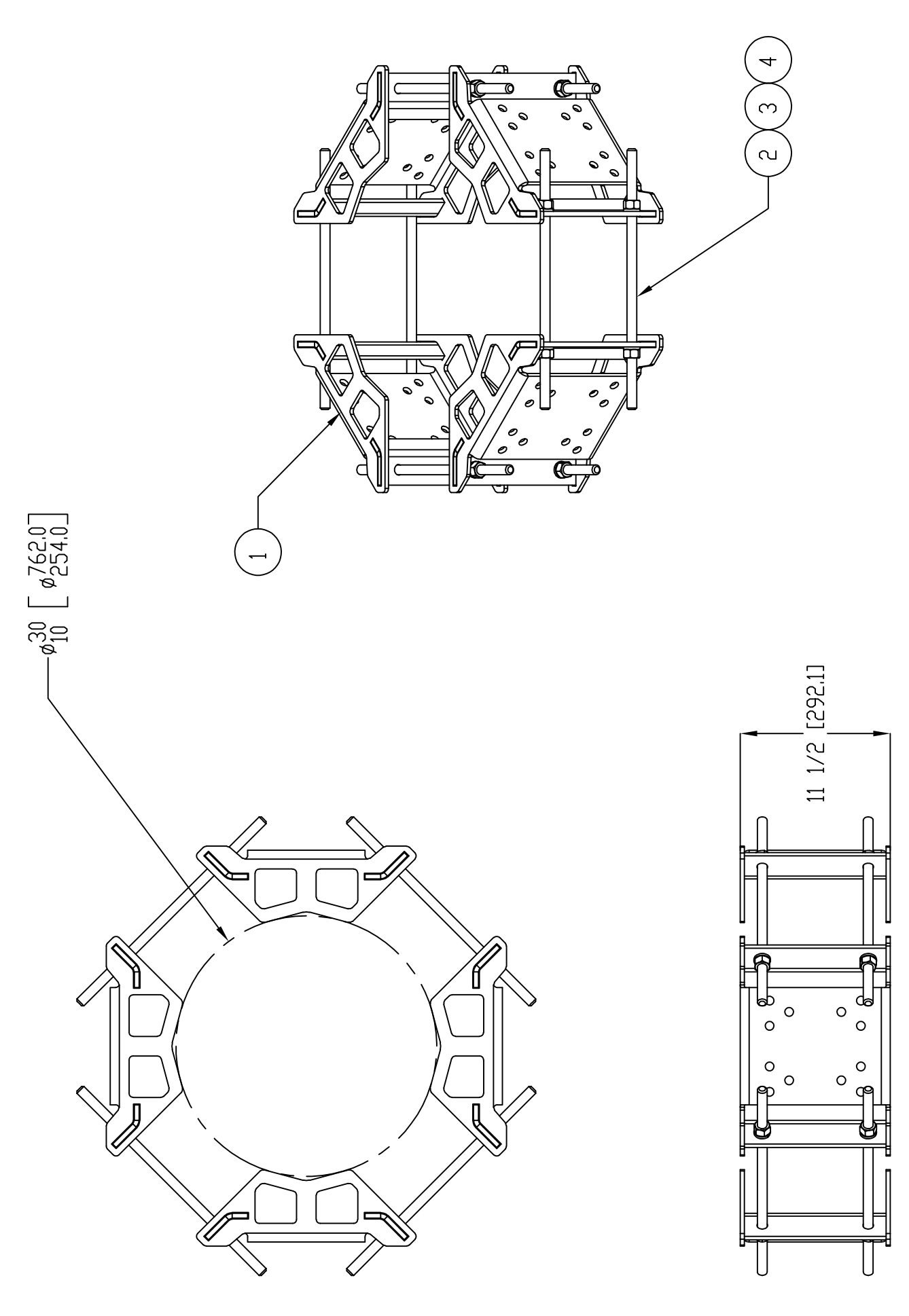

ELECTRICAL LEGEND

- NEW
- EXISTING
- PANEL BOARD, SURFACE MOUNTED
- DRY TYPE TRANSFORMER
- METER
- CIRCUIT BREAKER
- NON-FUSIBLE DISCONNECT SWITCH, MOUNTED 54" A.F.F.
- FUSIBLE DISCONNECT SWITCH, MOUNTED 54" A.F.F.
- TRANSIENT VOLTAGE SURGE SUPPRESSOR WITH BUILT-IN FUSES, SURFACE MOUNTED
- DUPLEX OUTLET, SURFACE MOUNTED, 20 AMPS, 125 VOLTS, SINGLE PHASE
- JUNCTION BOX, SURFACE MOUNTED 18" A.F.F.
- KEYED SWITCH, SURFACE MOUNTED
- WALL MOUNTED, ENCLOSED, AND GASKETED INDUSTRIAL INCANDESCENT FIXTURE WITH ONE 100 AMP LAMP MOUNT 72" A.F.F.
- EXPOSED WIRING
- HOME RUNS, MINIMUM #10 + 1#10G IN 3/4" CONDUIT U.O.N.
- ABOVE FINISHED FLOOR
- UNLESS OTHERWISE NOTED
- WEATHERPROOF
- GROUND FAULT INTERRUPTER

ELECTRICAL NOTES

- ALL ELECTRICAL WORK SHALL CONFORM TO THE REQUIREMENTS SET FORTH IN THE NATIONAL ELECTRICAL CODE (NEC) AS WELL AS APPLICABLE STATE AND LOCAL CODES.
- ALL ELECTRICAL ITEMS SHALL BE U.L. APPROVED OR LISTED AND PROCURED PER SPECIFICATION REQUIREMENTS.
- THE ELECTRICAL WORK INCLUDES ALL LABOR AND MATERIAL DESCRIBED BY DRAWINGS AND SPECIFICATION, INCLUDING INCIDENTAL WORK, TO PROVIDE COMPLETE, OPERATING AND APPROVED ELECTRICAL SYSTEM.
- CONTRACTOR SHALL PAY FEES FOR PERMITS, AND BE RESPONSIBLE FOR OBTAINING SAID PERMITS AND COORDINATION OF INSPECTIONS.
- ELECTRICAL AND TELCO WIRING INSIDE A BUILDING SHALL RUN IN EMT OR SCHEDULE 40 PVC, PER PLAN. (AS PERMITTED BY CODE)
- ELECTRICAL AND TELCO WIRING OUTSIDE A BUILDING AND EXPOSED TO WEATHER SHALL BE IN WATER TIGHT GALVANIZED RIGID STEEL CONDUITS OR SCHEDULE 80 PVC (AS PERMITTED BY CODE) AND, WHERE REQUIRED, IN LIQUID TIGHT FLEXIBLE METAL OR NONMETALLIC CONDUITS.
- BURIED CONDUIT SHALL BE SCHEDULE 40 PVC, U.O.N.
- ELECTRICAL WIRING SHALL BE COPPER WITH TYPE XHHW, THHN, OR THIN INSULATION, (PER PLAN).
- RUN ELECTRICAL CONDUIT BETWEEN ELECTRICAL UTILITY DEMARCATION POINT AND T-MOBILE CELL SITE ELECTRICAL PANEL/PEDESTAL AS INDICATED ON THIS DRAWING. PROVIDE FULL LENGTH PULL ROPES, COORDINATE INSTALLATION WITH UTILITY COMPANY.
- RUN TELCO CONDUITS BETWEEN TELEPHONE UTILITY DEMARCATION POINT AND T-MOBILE CELL SITE TELCO SERVICE CABINET AND EQUIPMENT CABINET(S) AS INDICATED ON THIS DRAWING. PROVIDE FULL LENGTH PULL ROPES AND TRUE TAPE IN INSTALLED CONDUITS.
- WHERE CONDUIT BETWEEN BITS AND T-MOBILE CELL SITE ELECTRICAL PEDESTAL AND BETWEEN BITS AND T-MOBILE CELL SITE TELCO SERVICE CABINET ARE UNDERGROUND, USE PVC #40 CONDUIT. ABOVE THE GROUND PORTION OF THESE CONDUITS SHALL BE FLEXIBLE CONDUIT.
- ALL EQUIPMENT SHALL HAVE NEMA 3R ENCLOSURE.
- WHERE APPLICABLE, POWER PEDESTAL IS SUPPLIED BY T-MOBILE
- CALL U.S.A. 1-800-642-2444 24 HOURS PRIOR TO COMMENCING ELECTRICAL OR TELCO WORK.
- CONTRACTOR SHALL COORDINATE WITH UTILITY COMPANY FOR FINAL AND EXACT WORK/MATERIALS REQ. AND CONSTRUCT TO UTILITY COMPANY ENGINEERING PLAN AND SPECIFICATIONS ONLY.
- CONTRACTOR SHALL FURNISH AND INSTALL ALL CONDUIT, PULLWIRES, TUBES, BULBS, CONDUIT, CONDUIT FITTINGS, TRAYING, ETC., WELL, AND INCLUDE ANY UTILITY COMPANY REQ. IN SCOPE OF WORK.

PROPRIETARY INFORMATION
THE INFORMATION CONTAINED IN THIS SET OF DRAWINGS IS PROPRIETARY BY NATURE. ANY USE OR DISCLOSURE OTHER THAN THAT WHICH RELATES TO PEAK SITE-COM IS STRICTLY PROHIBITED

CLIENT:
T-Mobile
T-MOBILE WEST LLC
1755 Creekside Oaks Drive, Suite 190 • Sacramento, CA 95833

PROJECT INFORMATION:
RED PEAK WEST
2000 FIRST AVE
SPARKS, NEVADA 89431

| REV. | DATE | DESCRIPTION | BY |
|------|---------|--------------|-----|
| 1 | 7-15-20 | 90% CDS | ALP |
| 2 | 8-3-20 | 100% CDS | VRT |
| 3 | 8-6-20 | rev 100% CDS | VRT |

COORDINATING ENGINEER:
Peek Site-Com
12852 Earhart Ave, Suite 101
Auburn, California 95602
Phone (530) 885-6160
E-Mail: info@peeksitecom.com

SEAL:
SITE #
CHK:
DRAWN BY:
SC09320
ALP
SHEET TITLE:
ELECTRICAL SHEET

SHEET NUMBER:
E-10
REVISION:

LOAD CENTER "PPC" PANEL SCHEDULE

| NO. | LOAD DESCRIPTION | ØA | ØB | AMP/POLE | ØA | ØB | LOAD DESCRIPTION | NO. |
|-----|------------------|-------|----|----------|-----|----|------------------|-----|
| 1 | NEW 6160 CABINET | 8500 | - | 100/2 | - | - | SPACE | 2 |
| 3 | - | 8500 | - | 20/1 | 500 | - | RECEPT | 4 |
| 5 | (E) BITS CABINET | 10000 | - | 100/2 | - | - | SPACE | 6 |
| 7 | - | 10000 | - | - | - | - | SPACE | 8 |
| 9 | SPARE | - | - | 20/1 | - | - | SPACE | 10 |
| 11 | SPACE | - | - | - | - | - | SPACE | 12 |
| 13 | SPACE | - | - | - | - | - | SPACE | 14 |
| 15 | SPACE | - | - | - | - | - | SPACE | 16 |
| 17 | SPACE | - | - | - | - | - | SPACE | 18 |
| 19 | SPACE | - | - | - | - | - | SPACE | 20 |
| 21 | SPACE | - | - | - | - | - | SPACE | 22 |
| 23 | SPACE | - | - | - | - | - | SPACE | 24 |
| 25 | SPACE | - | - | - | - | - | SPACE | 26 |
| 27 | SPACE | - | - | - | - | - | SPACE | 28 |
| 29 | SPACE | - | - | - | - | - | SPACE | 30 |

TOTAL CONNECTED (DISPOSED) VA... 37560L
TOTAL CONNECTED (FUTURE) VA... 37560L
TOTAL CONNECTED (P+F) VA... 37560L
DEMAND LOAD VA... 37560L

THE ASSUMED CONTINUOUS VALUES OF 125% OF ADJUSTED LOAD FOR ALL FEEDERS, BRANCHES & RECEIVERS IN 6160 (BITS) 37560W/240V/150.25A 150.25A < 200A

NEW 100/2 C.B. TO BE INSTALLED FOR NEW 6160 CABINET

PANEL SCHEDULE

SCALE: N.T.S. 1

NOTE: CONTRACTOR TO VERIFY THAT POWER UPGRADE (RED PEAK WEST POWER UPGRADE DATED 7-27-20) IS TO BE COMPLETED BEFORE ANY NEW TECHNOLOGIES ARE POWERED UP

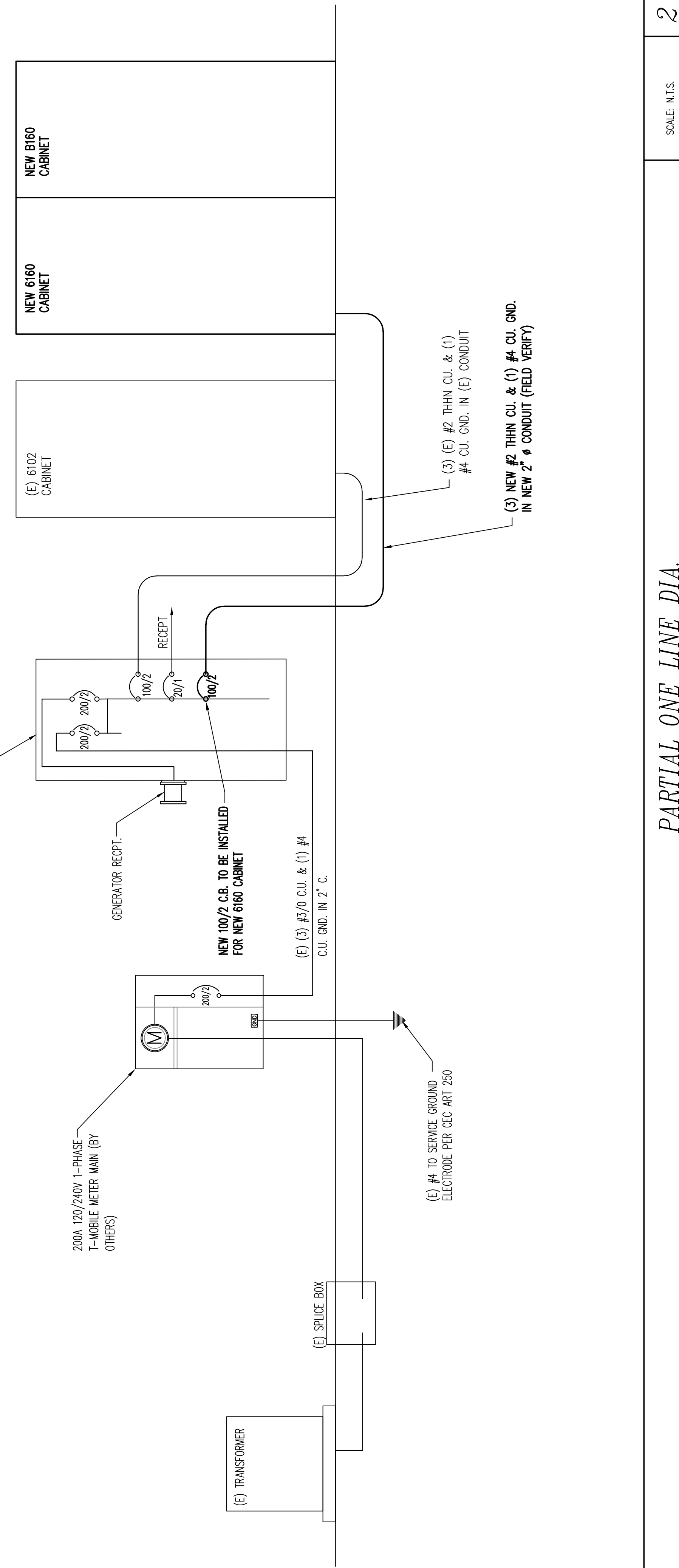

PARTIAL ONE LINE DIA.

SCALE: N.T.S. 2

Existing



Proposed



view from Ranger Road looking east at site

Existing



Proposed



Proposed T-Mobile
Installation

view from Opal Bluff Drive looking southeast at site

Existing



Proposed



view from Flint Springs Drive looking south at site

Existing



Proposed



Proposed T-Mobile
Installation

view from W. Golden Valley Road looking southwest at site

SC09320A Red Peak West
2000 First Avenue, Sparks, NV
Photosims Produced on 9-11-2020

Existing



Proposed



Proposed T-Mobile
Installation Not Visible

view from W. First Avenue looking northwest at site

Existing



Proposed



Proposed T-Mobile Installation

view from Dandini Boulevard looking northwest at site

Existing



Proposed



view from Dandini Boulevard looking northwest at site

Existing



Proposed



view from Dandini Boulevard looking northeast at site

